



PC



IR



GPS

OPTIONAL

MCL160

Great performance and light range

The MCL160 is a compact LED marine lantern, solar self-contained, with great optical efficiency and range, fitted with LED diodes of high intensity, reaching a nominal range up to 7 nautical miles in a compact-sized equipment.

Optimized lens system

Its luminous source consists of an innovating lens system especially designed to take the maximum profit of LED diodes, thus obtaining an output of up to 180 Cd/W.

Replaceable high capacity battery

The battery is replaceable, thus the complete lantern disposal is not necessary at the end of battery's life. In addition, due to its large capacity in relation to its compact size, energy availability is ensured at all times.

Designed according to IALA Recommendations.



FEATURES

- *High-efficiency luminous system.*
Up to 7 nm ($T=0.74$), 9 nm ($T=0.85$).
- *Vertical divergence up to 12° (50% I_0).*
- *360° horizontal output.*
- *Average operation lifetime over 10 years.*
- *All components can be easily replaced.*
- *IP 68 watertightness degree (immersion resistant).*
- *High shock resistance.*
- *Anti-humidity device in order to avoid condensation.*
- *Autonomy without solar charging up to 300 hours.*
- *Automatic energy management, according to solar radiation.*
- *Programming, configuration and operating status via PC or IR programmer.*
- *PATENTED OPTICAL SYSTEM.*

MCL160

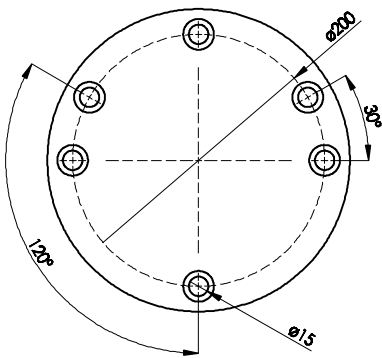
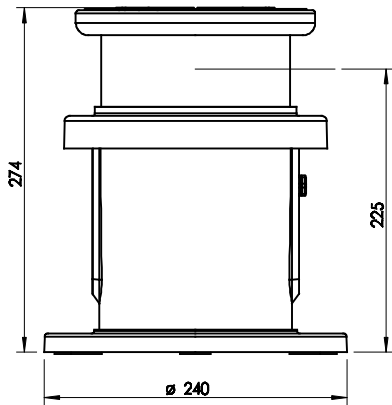

Technical Features

Light source:	Ultra-bright LED diodes, with high-precision acrylic lenses.
LED average life:	More than 100,000 hours.
Flash rhythms:	256 rhythms (6 nos. user selectable).
Solar module:	1 no. of 2 W.
Battery:	14.4 Ah, Lead Crystal®, maintenance-free.
Base:	Glass-fibre reinforced polyamide PA66-GF30.
Lens cover:	UV stabilized acrylic.
Watertightness degree:	IP 68.

Options

- PC programming kit.
- Bird deterrent spikes.
- MCL 160-SYNC (GPS synchronization).
- Other specifications available under request.
- Other battery capacities available.

Peak intensities (Cd)

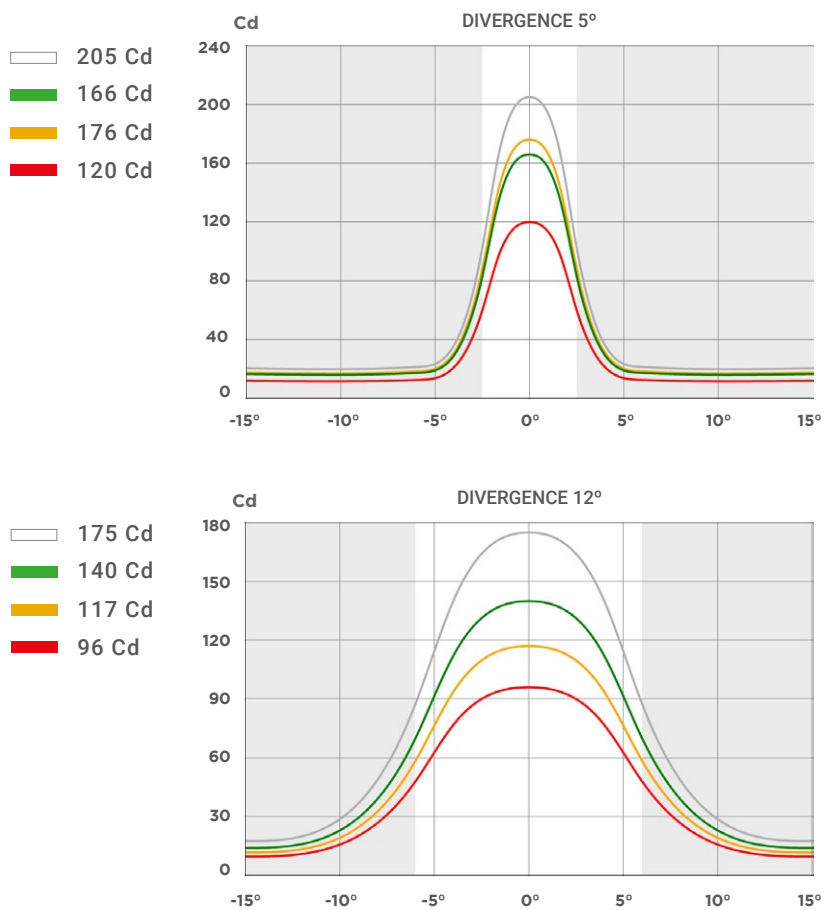

I Specifications subject to change without previous notice.
Luminous ranges will be affected depending on latitude, flash rhythms and chosen options.